

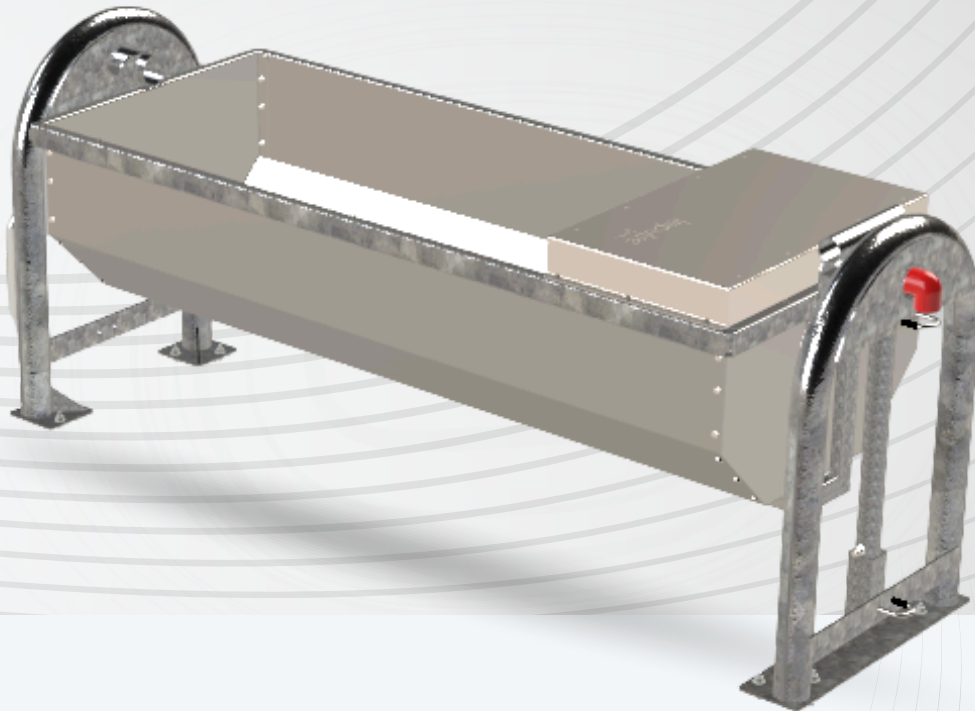

Bebedouro basculante 1,5 Metros



Assista ao vídeo do produto

Características e benefícios:



Bóia de alta vazão

Abastecimento rápido e contínuo.



Facil Limpeza

Bebedouros basculantes com superfícies lisas que evitam acúmulo de sujeira



Durabilidade

Materiais resistentes à corrosão e baixa manutenção.

Bebedouro basculante de 1,5 metros, desenvolvido para garantir eficiência no abastecimento e mais conforto para as vacas. Possui fácil higienização, mantendo a água sempre limpa, além de estrutura robusta, oferecendo alta resistência, durabilidade e baixa manutenção.

Descritivo Técnico

 Capacidade	250 Litros
 Comprimento	1,5 Metros
 Largura	57 cm
 Altura	63 cm
 Profundidade	35 cm
 Estrutura	Aço inox 1,5mm
 Acabamento	Galvanizado a fogo

